

ILLUMINATING EVERY NICHE



OBSTRUCTION LIGHTING



البابطين للطاقة و الاتصالات
AL-BABTAIN POWER & TELECOM

OBSTRUCTION LIGHTING

The Obstruction Lighting high quality speaks out. Its extraordinary quality is guaranteed as its design is European based. In addition to that, its durability to tough conditions grants reliability from the customers.

IP Chart

LUMINAIRE	IP
F21	54
F22	54



OBSTRUCTION LIGHTING

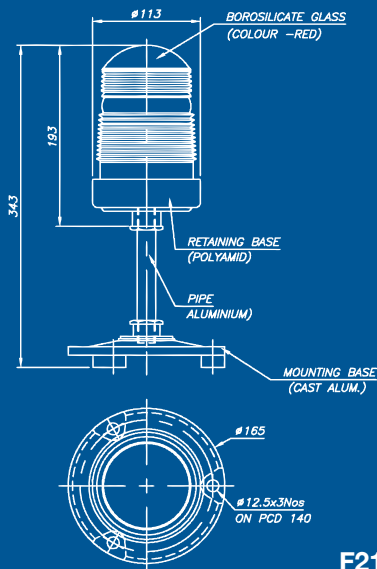

F21

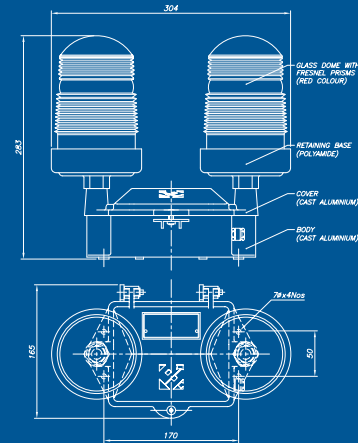

F22

Application

F-Series luminaire is used to indicate the presence of protruding objects near the movement areas of aerodrome. It is fixed on super structures in certain positions, which might cause a collision risk near aerodromes, or helpads that can be caused at night.

Apart from the areas around air bases, it is necessary to mark very high obstacles protruding into airplane or helicopter traffic zones i.e. radio antennas, chimney stacks, high masts and high tension lines.

As a general rule one or more light should be fixed on the top of the F- Series or on its edges when it is massive in shape. The number of lights should be sufficient to be seen in all azimuthal directions as per ICAO & FAA standards with respect to low intensity beaconing light fittings.

Construction Features

Construction:

Retaining Base (F21):

The retaining base is made of Polyamide by injection molding in yellow color. A M21 threaded hole is provided for mounting and a die cast aluminum mounting base can be supplied optionally.

Body (F22):

The body is made of cast aluminum of low copper content for corrosion resistance. The body accommodates the electronic control device, circuit connector, cable gland and 4 holes for obstruction light mounting. The change over relay and circuit connector accommodated inside the body are fixed on a removable aluminum plate for easy maintenance.

Lamps (F21):

Type: Incandescent signal lamp (Long Life)
 Wattage: 55 W
 Rating: 230V/50-60 Hz
 Average Lamp Life: 8000 hours
 Brand: Sylvania
 Origin: France
 Operation: Continuous without pulse

Lamps (F22):

Qty: 2 nos. per set
 Type: Incandescent signal lamp (Long Life)
 Wattage: 55 W
 Rating: 230V/50-60 Hz
 Average Lamp Life: 8000 + 8000 hours
 Brand: Sylvania
 Origin: France
 Operation: Continuous without pulse



www.al-babtain.com.sa



البابطين للطاقة و الاتصالات
AL-BABTAIN POWER & TELECOM